

▴  
**Creating Community  
Sailing Access in  
Weehawken Cove**

February 2, 2023





# Summary



## **A Proposal for a Hoboken Community Sailing Center**

The proposed Hoboken Community Non-Profit Sailing Center seeks to provide access to sailing for all members of the Hoboken community, regardless of age, skill level, or economic means. The center aims to promote the sport of sailing and provide opportunities for personal growth and development through sailing activities. The center will operate out of an area near the shore of Weehawken Cove, and will offer recreational sailing opportunities, and sailing education. The center will be run by a dedicated group of volunteers and will be supported by donations from members and the community.



# Hoboken's Rich Sailing History

Sailing has a rich history in Hoboken from Henry Hudson, to being the original home of the New York Yacht Club, and the home of the first boat (named "America"—shown here) to win the America's cup (the Super Bowl of Sailing).





# The Unique Opportunity for Hoboken

- Hoboken has a unique opportunity to create an easily accessible world class sailing venue in Weehawken Cove.
- Currently there are no safe or convenient places to launch and store small sailboats (dinghies) in Hoboken.
- Small sailboats are low cost, easy to maintain, and are the foundation of all youth-based sailing programs around the world.
- All of the skills learned on small boats translate to larger boats





# Why Sailing?

Building community through the sport of sailing



- Sailing is an activity that you can participate in at almost any age. Men and women participate from childhood well into their senior years.
- Children can begin competing in the International Opti Class (sailing independently) at 8 years old.
- Sailing offers an alternative to other “ball sports” and facilitates cognitive development in addition to athleticism.
- Sailing requires a very small amount of land use compared to other sports since the “field” is on the water and the field requires no maintenance.
- Sailing has a rich history in Hoboken from Henry Hudson, to being the original home of the New York Yacht Club, and the home of the first boat (named America) to win the America’s cup (the Super Bowl of Sailing).
- Sailboat racing is enjoyed at the Olympic, collegiate, high school, and youth levels. The sport may be unfamiliar to people living in urban areas, but in seaside communities around the US, and internationally it is very popular.



# Why Dinghies?

A Dinghy is a small non-motorized Sailboat.

- Learning to sail in small boats is the best way to learn. Every skill you learn in a small boat can translate up to larger boats
- They are safer than larger boats. They are less expensive and require less maintenance.
- They don't have engines and are environmentally friendly
- They can be beach launched and removed from the water easily and do not require docks or a marina to operate.

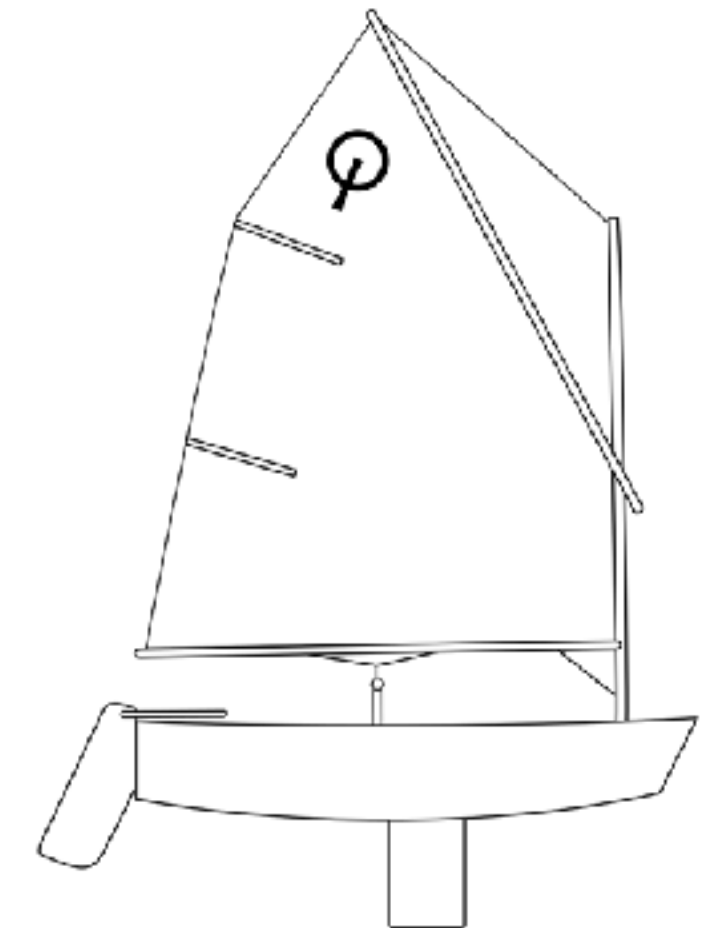

Three popular dinghies from left to right are the 420, the Sunfish and the Opti



# Why Weehawken Cove?

Protection from strong currents and boat traffic make it an ideal sailing location

- New York Harbor and the lower Hudson River are tidal waterways. Strong tidal currents flow in the Hudson River and alternate directions, North and South, approximately every six hours throughout the day.
- Weehawken Cove is a unique feature in NY Harbor offering protection from the strong currents and boat traffic. Henry Hudson first anchored his boat in Weehawken Cove for protection from the strong tides in 1609.
- Weehawken Cove has access points that will make it easy to launch boats without having to fight currents, making access to sailing more efficient and safer.
- The public walkways around the cove provide unique access points for spectators to watch races or to enjoy watching boats sail. Sailboats provide a beautiful backdrop for seaside communities and cities.
- The cove is large enough for leisure sailing, sailing lessons, and sailboat racing.

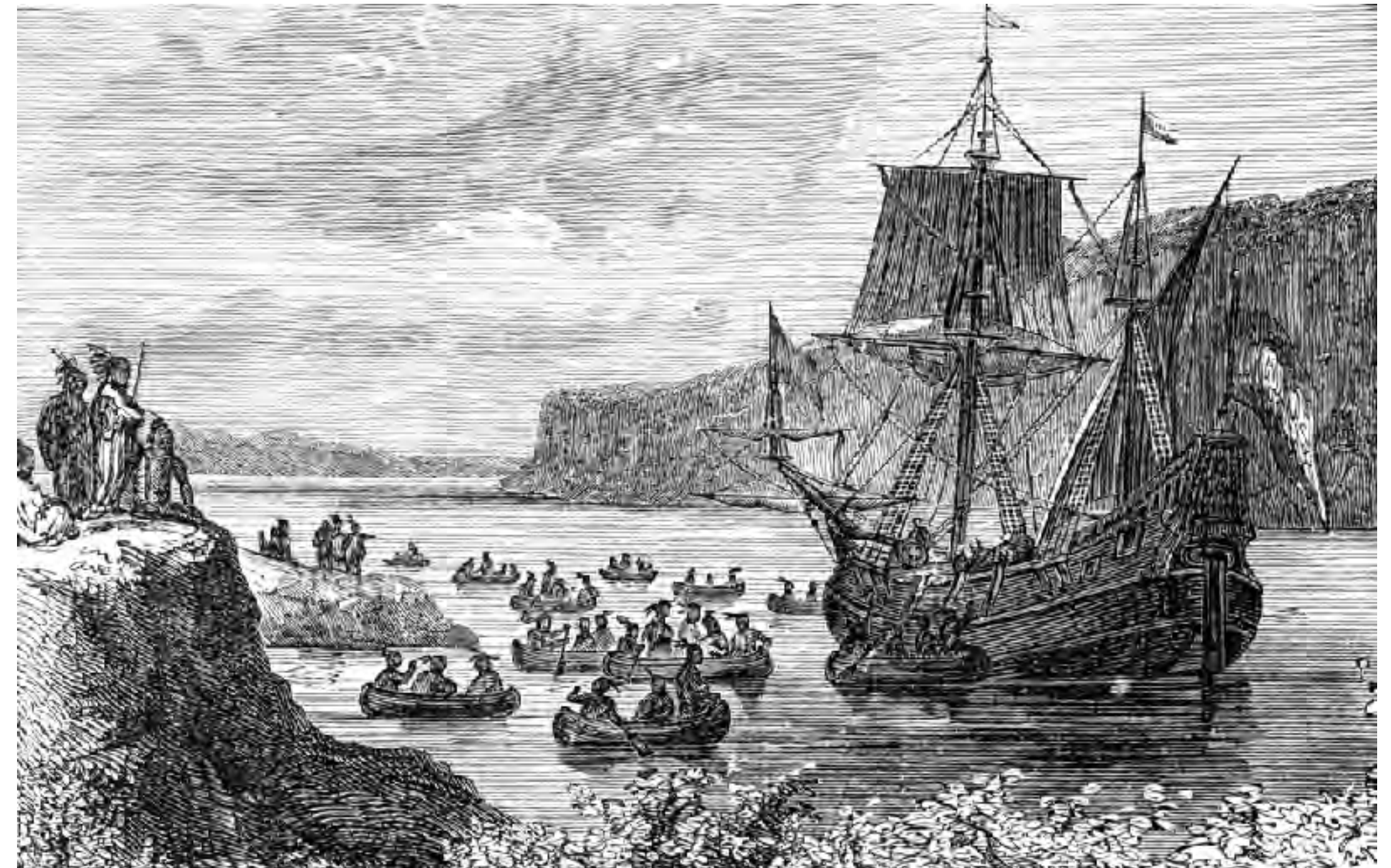

Henry Hudson first anchored his boat in Weehawken Cove for protection from the strong tidal currents in 1609.



# Currents

Strong tidal currents flow in the Hudson River and change direction (North and South), approximately every six hours throughout the day.

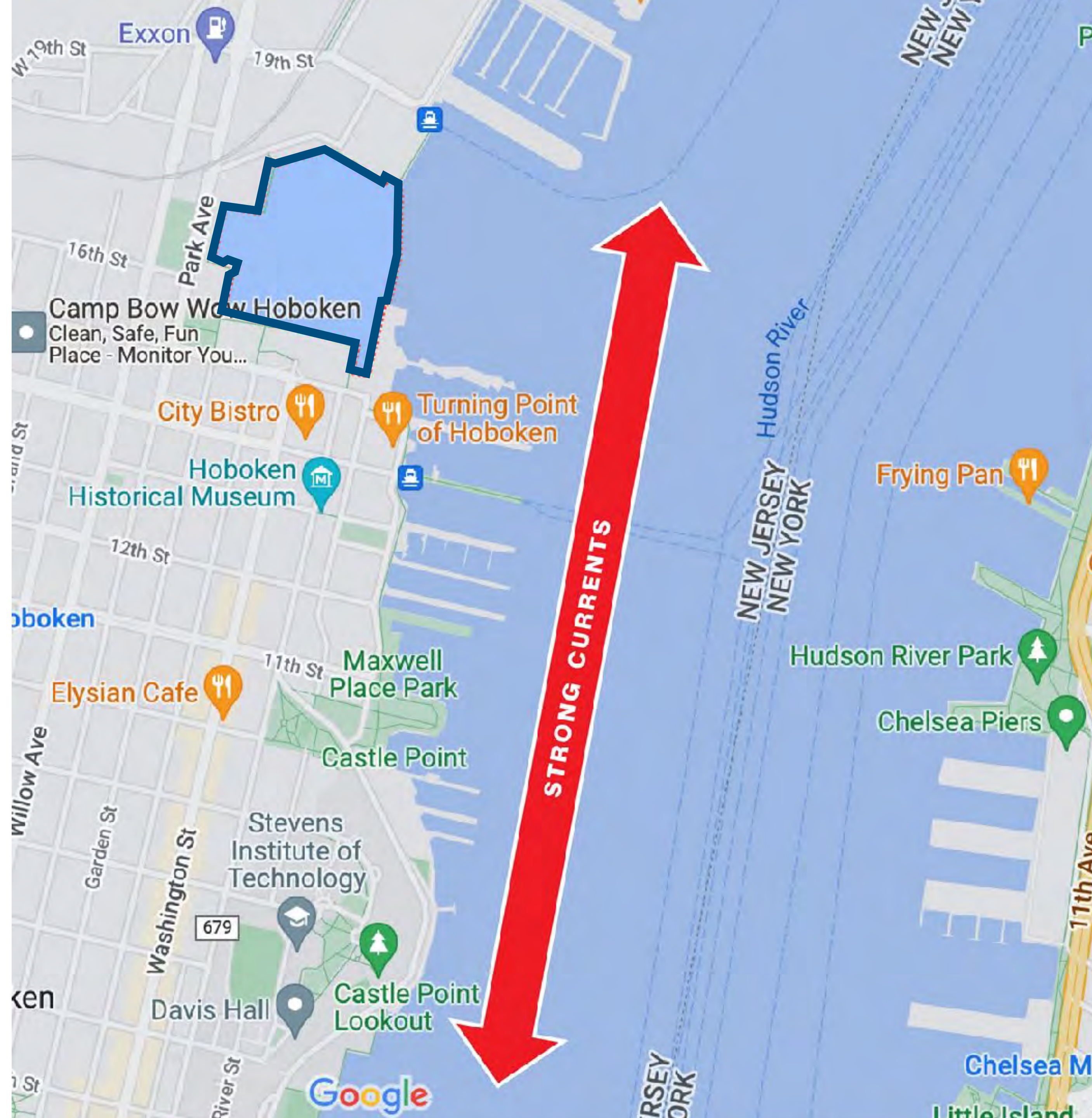



# Protection

Weehawken Cove's location provides shelter from the the current and commercial boat traffic.

Being able to launch a boat directly from the shore of the cove provides safe access.





# Proof of Concept

A group of sailors take to the water to sail dinghies in Weehawken Cove



- Since the derelict boats were removed from Weehawken Cove in the summer of 2022, a group of passionate sailors have been launching small sailboats (called Sunfish) from the beach in front of the Hoboken Cove Community Boathouse.
- We sail to the cove where we've conducted races and practice sessions and the cove is an excellent place to race and to sail for fun; there is plenty of room, no boat traffic and it is protected from strong currents.

- Getting to Weehawken Cove from Maxwell beach is difficult due to strong currents and is a barrier to entry for new sailors and children.



# Hoboken High School Sailing Club

- In 2022 Hoboken High School started a sailing club for the first time. There were about 8 students signed up for the club. One of the biggest challenges for the club was access to the water. The boats were hosted by the Hoboken Sailing Club on Pier 12, but they had difficulty getting out because of the strong currents.
- If there was storage and access near Weehawken Cove, Hoboken High School could have one of the shortest times from the classroom to the water in the country. Many high school programs have to bus children to the water– even in coastal communities. Hoboken High School has the opportunity to build an amazing sailing team. "Time on the water" is everything since it affords the opportunity to practice.
- Sailing is a sport that provides opportunities for students who may not be good at, or interested in ball sports. It is a team sport (2 person boats) and boats can sail individually or as teams against each other. It is non-contact and is safer than contact sports.



Students from the Hoboken High School Sailing Club practicing during the 2022 spring season. The club needs a proper location to launch and sail their boats safely. They currently have 4 boats.



# Open the Gates!

Opening the gates on 15th Street would be a simple first step



- Weehawken Cove has a large access ramp but is closed off with fixed gates. The gates are located on 15th street between Hudson Street and Shipyard Lane
- Installing a gate that can be opened would allow sailboats to launch easily in the cove
- Prohibiting motorized boats and jet skis is recommended
- Making the opening wide enough for boat dollies (9 feet) is recommended.

There is access from the street which is helpful for bringing boats on dollies to the boat ramp





# What's Needed

A small amount of space can go a long way

- A secure area (40'x70') to store boats and equipment that has protection from theft and vandalism (locked fencing).
- Ideally this area could be in a location that could have a permanent covered facility or community boathouse built in the future.
- A hose with freshwater so salt water can be rinsed off of boats and equipment.
- A wide 8' pathway from the storage area to the beach area(s) of Weehawken Cove so boats can be wheeled on dollies back and forth to the water and put away.
- An access path wide enough so a vehicle could tow the the boats for the high school to travel to regattas
- Proximity to the shore of Weehawken Cove



The space near the site of the Monarch Site would be an ideal location for boat storage with easy access to the cove.



# Thank You

For more information  
please contact:  
Ken Zorovich  
[ken@zokuhome.com](mailto:ken@zokuhome.com)  
201-920-2214